

# Ecoflam

HEAVY OIL RANGE

## MAXFLAM - OILFLAM



---

[www.ecoflam-burners.com](http://www.ecoflam-burners.com)

## RANGE OVERVIEW

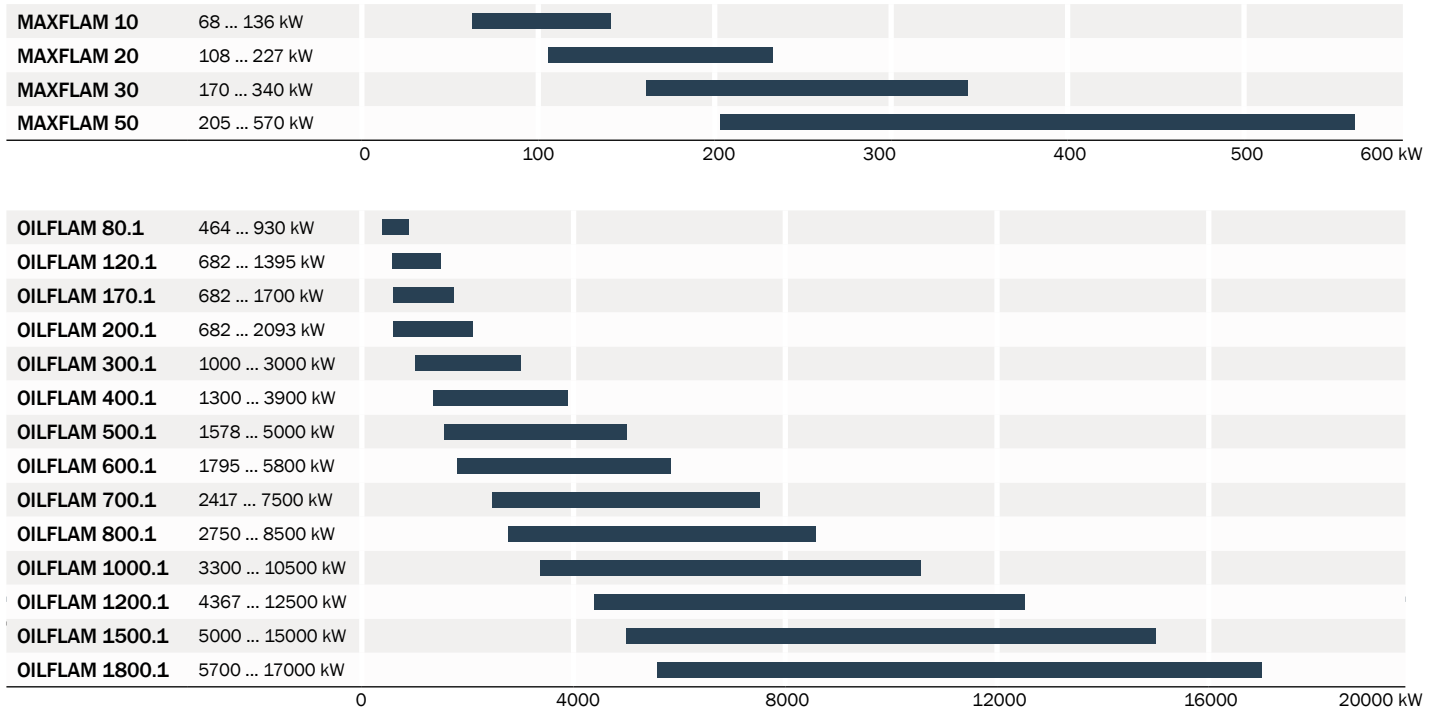

## MAIN FEATURES

- All models are suitable to work with heavy oil up to 380 cSt (50 °E) at 50 °C
- Two stage version with electric servomotor available up to model OILFLAM 400.1
- Version with fully electronic Burner Management System available for all models
- Integrated electrical panel complete with pre-heater management system
- Digital thermoregulator integrated on the front panel to grant temperature stability of the fuel (from OILFLAM 300.1)
- Self-cleaning filter installed in the pre-heater in order to keep the nozzle clean from OILFLAM 300.1
- Adjustable combustion head for easy regulation and matching with different combustion chambers
- Heavy oil electric heating system on board
- Ring system for oil preparation can be designed and supply on request

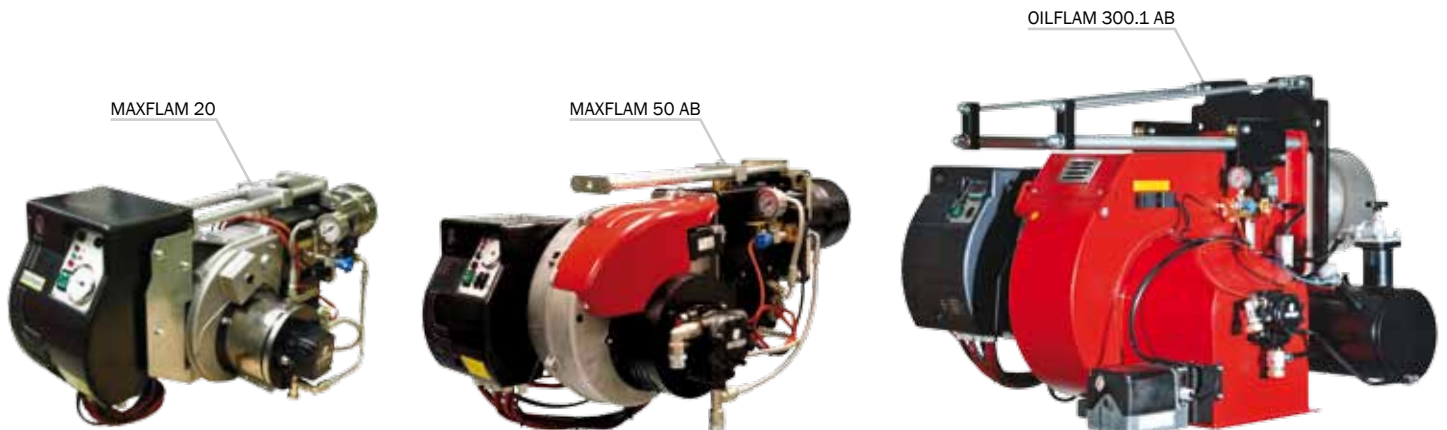

## CONFIGURATIONS

MAXFLAM range is available in the following operation modes:

<b>MAXFLAM</b>	One stage	MAXFLAM 10 ... 30
<b>MAXFLAM ... AB</b>	Two stages	MAXFLAM 30 ... 50 AB

OILFLAM range is available in the following operation modes:

<b>OILFLAM ... AB</b>	Two stages	OILFLAM 80.1 AB ... 400.1 AB
<b>OILFLAM ... PR</b>	Two stage progressive/modulating mechanical	OILFLAM 80.1 PR ... 1800.1 PR
<b>OILFLAM ... PRE</b>	Two stage progressive/modulating electronic	OILFLAM 80.1 PRE ... 1800.1 PRE

### Other available configurations:

- Continuous ventilation versions
- High temperature versions
- High viscosity versions suitable for 118 cSt (15° E) at 80°C available on request

### FUEL

- Heavy oil (max viscosity 380 cSt (50° E) at 50°C)

### EMISSIONS

Class	NOx mg/kWh
<b>1</b>	<b>250</b>
2	185
3	120

All models are in compliance with EN 267 European Standard

### CONFORM TO

All products are in accordance with the following directives:

- 2006/42/EC Machinery Directive
- 2014/30/UE EMC Directive
- 2014/35/UE Low Voltage Directive

OILFLAM 1000.1 PR



OILFLAM 1800.1 PR



Range | Models  
**MAXFLAM | 10 - 20 - 30 - 50**

- Fuel: heavy oil (max viscosity 380 cSt (50° E) at 50° C)
- Operation: one stage and two stages

### WORKING DIAGRAM

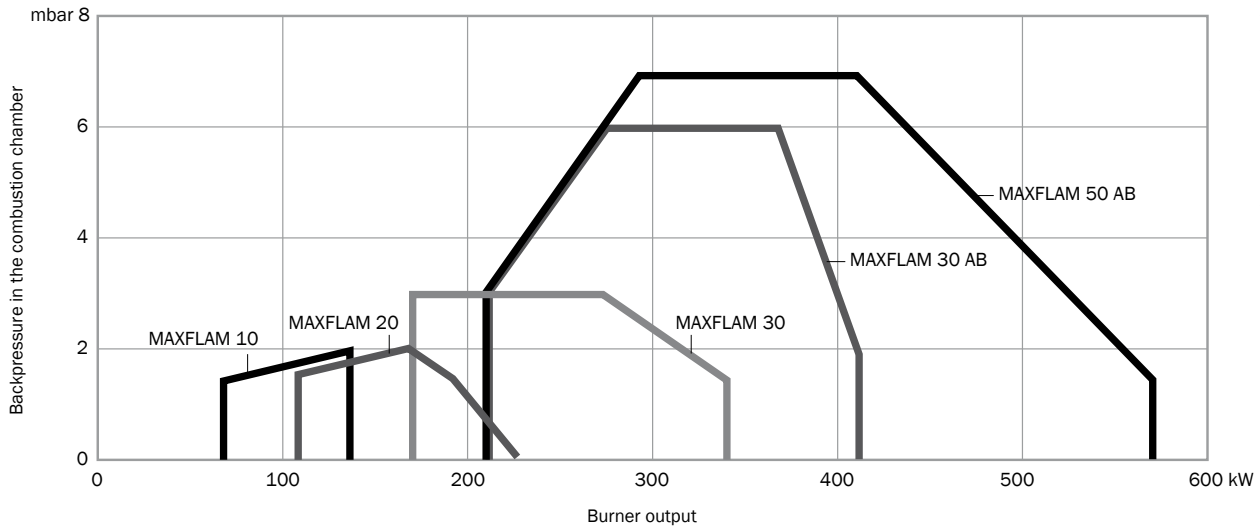

### TECHNICAL DATA

	Burner output (kW)	Flow rate (kg/h)	Power supply	Resistance (kW)	Motor (kW)	Operation
MAXFLAM 10	68 - 136	6 - 12	1/230V/50Hz	1,3	0,45	1 stage
MAXFLAM 20	108 - 227	9,5 - 20	1/230V/50Hz	1,95	0,45	1 stage
MAXFLAM 30	170 - 340	15 - 30	3/230-400V/50Hz	3,9	0,74	1 stage
MAXFLAM 30 AB	205 - 410	18 - 36	3/230-400V/50Hz	3,9	0,74	AB
MAXFLAM 50 AB	205 - 570	18 - 50	3/230-400V/50Hz	3,9	1,1	AB

### OVERALL DIMENSIONS

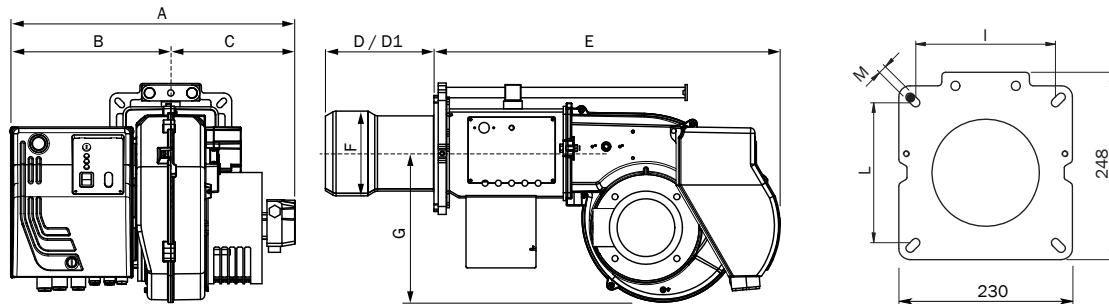

Dimensions in mm  
 Head length: D short / D1 long

	A	B	C	D	D1	E	F	G	I	L	M
MAXFLAM 10	520	290	230	205	325	535	130	201	160	160	M8
MAXFLAM 20	520	290	230	205	325	535	130	201	160	160	M8
MAXFLAM 30	562	302	260	210	330	653	160	280	185/200	185/200	M10
MAXFLAM 30 AB	562	302	260	205	325	653	170	280	185/200	185/200	M10
MAXFLAM 50 AB	562	302	260	205	325	653	170	280	185/200	185/200	M10

Range | Models  
**OILFLAM 80.1 - 120.1 - 170.1 - 200.1**

• Fuel: heavy oil (max viscosity 380 cSt (50°E) at 50°C)

**BURNERS**

two stages and two stage progressive or modulating with the installation of a power regulator and dedicated probes  
 (see page 102)

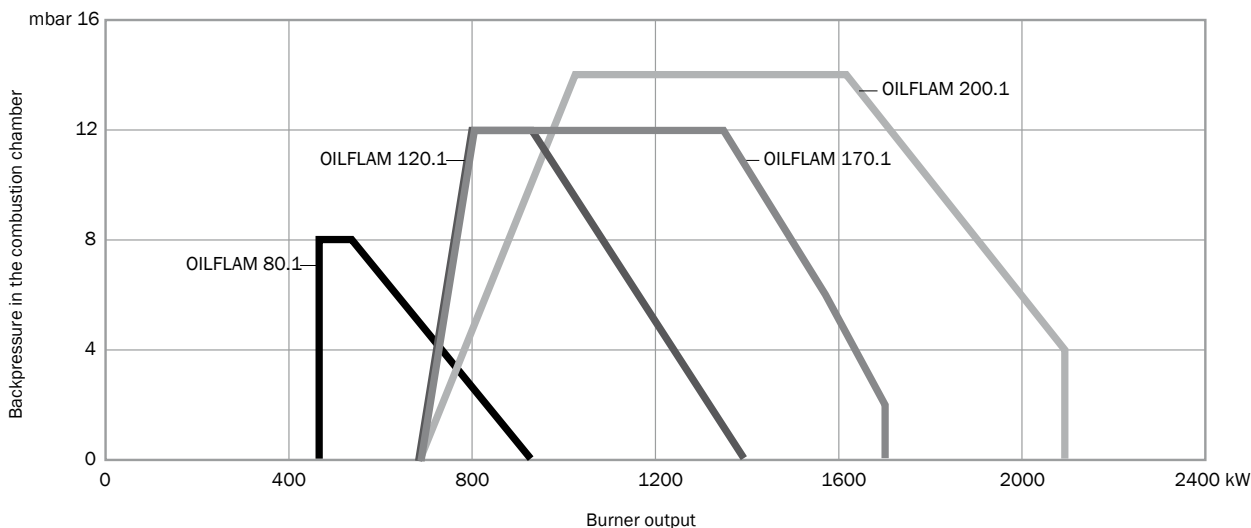

	Burner output (kW)	Flow rate (kg/h)	Power supply	Resistance (kW)	Motor (kW)	Operation
<b>OILFLAM 80.1</b>	464 - 930	41 - 82	3/230-400V/50Hz	4,7	1,5	AB, PR, PRE
<b>OILFLAM 120.1</b>	682 - 1395	60 - 122	3/230-400V/50Hz	7,1	2,2	AB, PR, PRE
<b>OILFLAM 170.1</b>	682 - 1700	60 - 148	3/230-400V/50Hz	9	3	AB, PR, PRE
<b>OILFLAM 200.1</b>	682 - 2093	60 - 184	3/230-400V/50Hz	10,5	4	AB, PR, PRE

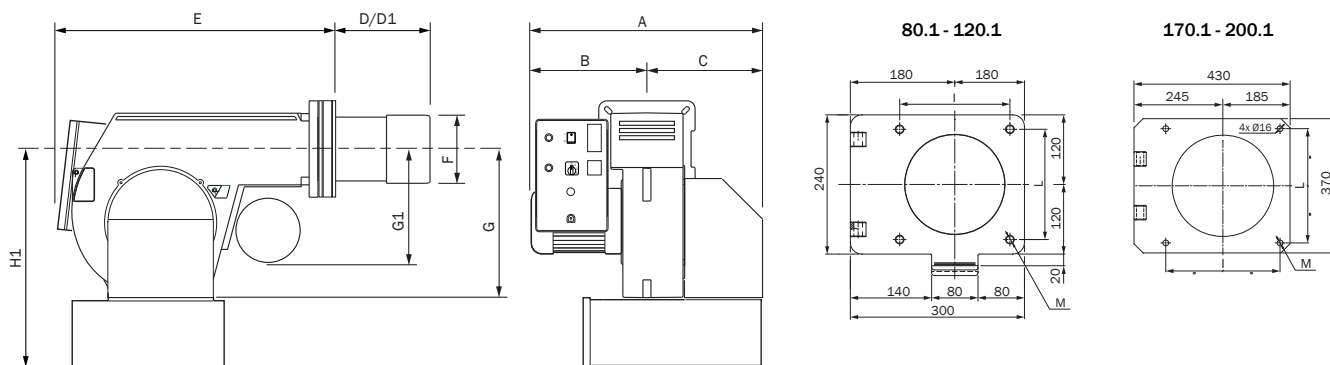

Dimensions in mm  
 Head length: D short / D1 long  
 \*: with silencer (optional)

	A	B	C	D	D1	E	F	G	G1	H1*	I	L	M
<b>OILFLAM 80.1</b>	758	388	370	170	310	600	185	390	440	600	190	190	M10
<b>OILFLAM 120.1</b>	758	388	370	170	310	600	185	390	440	600	190	190	M10
<b>OILFLAM 170.1</b>	920	450	470	280	480	710	250	420	390	680	315	315	M14
<b>OILFLAM 200.1</b>	920	450	470	280	480	710	270	420	390	680	315	315	M14

Range | Models  
**OILFLAM 300.1 - 400.1 - 500.1 - 600.1**

- Fuel: heavy oil (max viscosity 380 cSt (50° E) at 50° C)
- Operation: two stages and two stage progressive or modulating with the installation of a power regulator and dedicated probes (see page 102)

## WORKING DIAGRAM

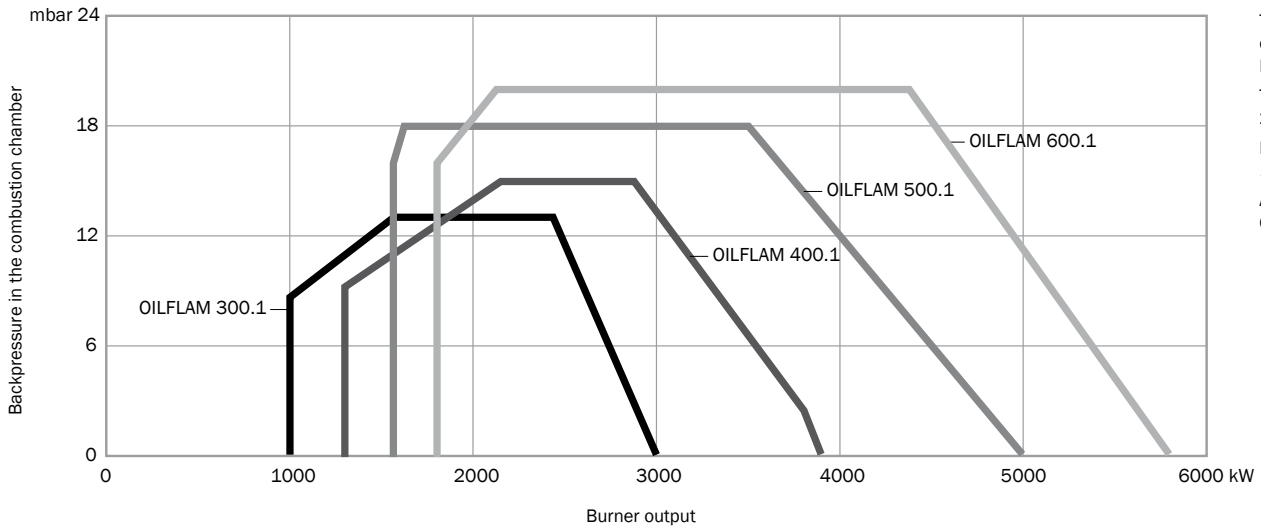

## TECHNICAL DATA

	Burner output (kW)	Flow rate (kg/h)	Power supply	Resistance (kW)	Motor (kW)	Operation
<b>OILFLAM 300.1</b>	1000 - 3000	88,5 - 264	3/400V/50Hz	18	7,5	AB, PR, PRE
<b>OILFLAM 400.1</b>	1300 - 3900	115 - 343	3/400V/50Hz	21	9	AB, PR, PRE
<b>OILFLAM 500.1</b>	1578 - 5000	140 - 440	3/400V/50Hz	24	11	PR, PRE
<b>OILFLAM 600.1</b>	1795 - 5800	159 - 510	3/400V/50Hz	24	15	PR, PRE

## OVERALL DIMENSIONS

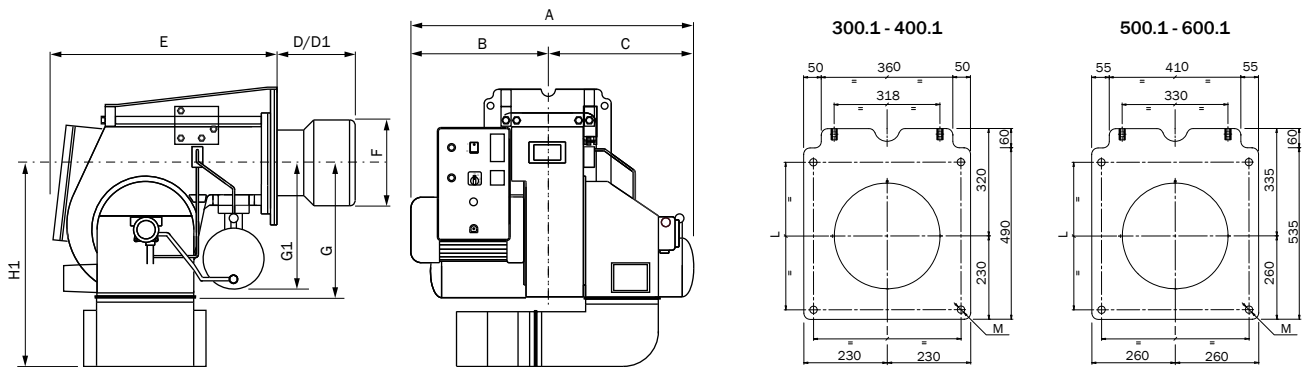

Dimensions in mm  
 Head length: D short / D1 long  
 \*: with silencer (optional)

	A	B	C	D	D1	E	F	G	G1	H1*	I	L	M
<b>OILFLAM 300.1</b>	1205	603	602	350	600	925	290	470	430	746	400	400	M16
<b>OILFLAM 400.1</b>	1205	603	602	350	600	925	320	470	430	746	400	400	M16
<b>OILFLAM 500.1</b>	1300	610	690	370	670	990	320	570	480	965	460	460	M16
<b>OILFLAM 600.1</b>	1300	610	690	370	670	990	320	570	480	965	460	460	M16

Range | Models  
**OILFLAM 700.1 - 800.1 - 1000.1 - 1200.1**

• Fuel: heavy oil (max viscosity 380 cSt (50°E) at 50°C)

**BURNERS**

two stage progressive or modulating with the installation of a power regulator and dedicated probes (see page 102)

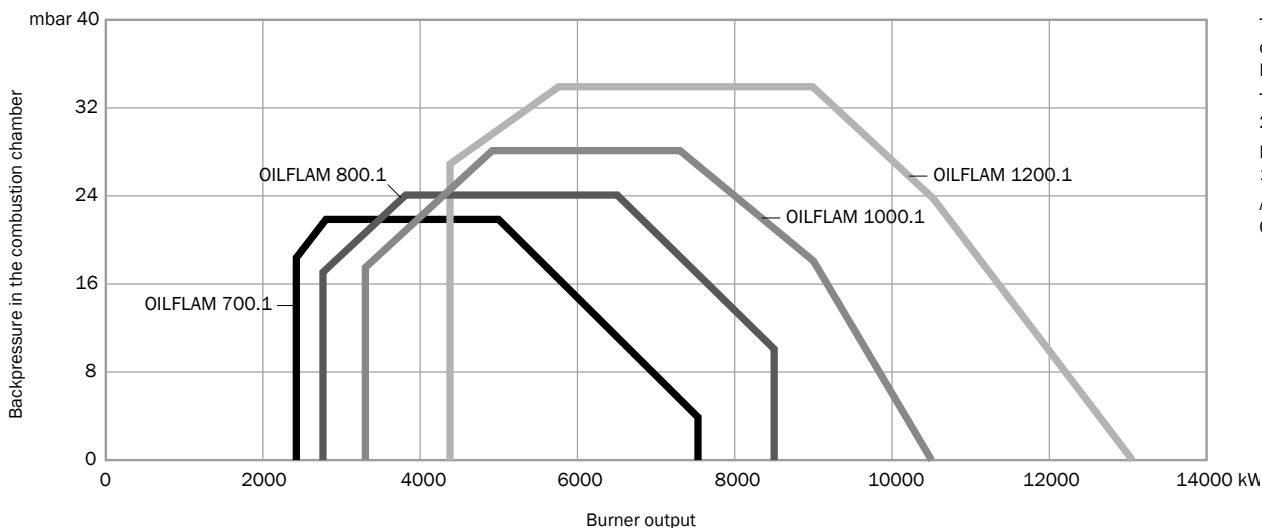

	Burner output (kW)	Flow rate (kg/h)	Power supply	Resistance (kW)	Motor (kW)	Operation
<b>OILFLAM 700.1</b>	2417 - 7500	214 - 660	3/400V/50Hz	30	15	PR, PRE
<b>OILFLAM 800.1</b>	2750 - 8500	243 - 748	3/400V/50Hz	30	18,5	PR, PRE
<b>OILFLAM 1000.1</b>	3300 - 10500	292 - 924	3/400V/50Hz	44	22	PR, PRE
<b>OILFLAM 1200.1</b>	4367 - 12500	386 - 1099	3/400V/50Hz	2x 30	37	PR, PRE

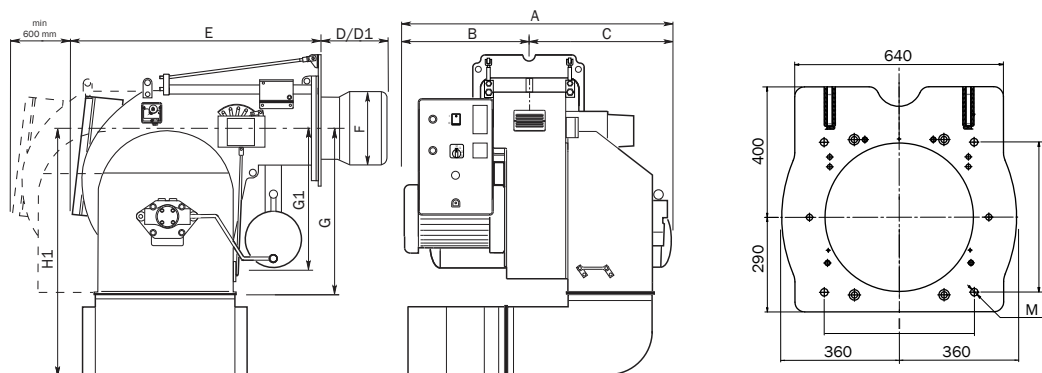

Dimensions in mm  
 Head length: D short / D1 long  
 \*: with silencer (optional)

	A	B	C	D	D1	E	F	G	G1	H1*	I	L	M
<b>OILFLAM 700.1</b>	1390	660	730	525	-	1240	385	775	520	1270	460	460	M20
<b>OILFLAM 800.1</b>	1480	660	820	535	-	1240	430	775	520	1270	460	460	M20
<b>OILFLAM 1000.1</b>	1505	685	820	535	-	1240	460	775	520	1270	460	460	M20
<b>OILFLAM 1200.1</b>	1750	800	950	535	-	1410	460	775	900	1270	460	460	M20

Range | Models  
**OILFLAM | 1500.1 - 1800.1**

- Fuel: heavy oil (max viscosity 380 cSt (50° E) at 50° C)
- Operation: two stages and two stage progressive or modulating with the installation of a power regulator and dedicated probes (see page 102)

**WORKING DIAGRAM**

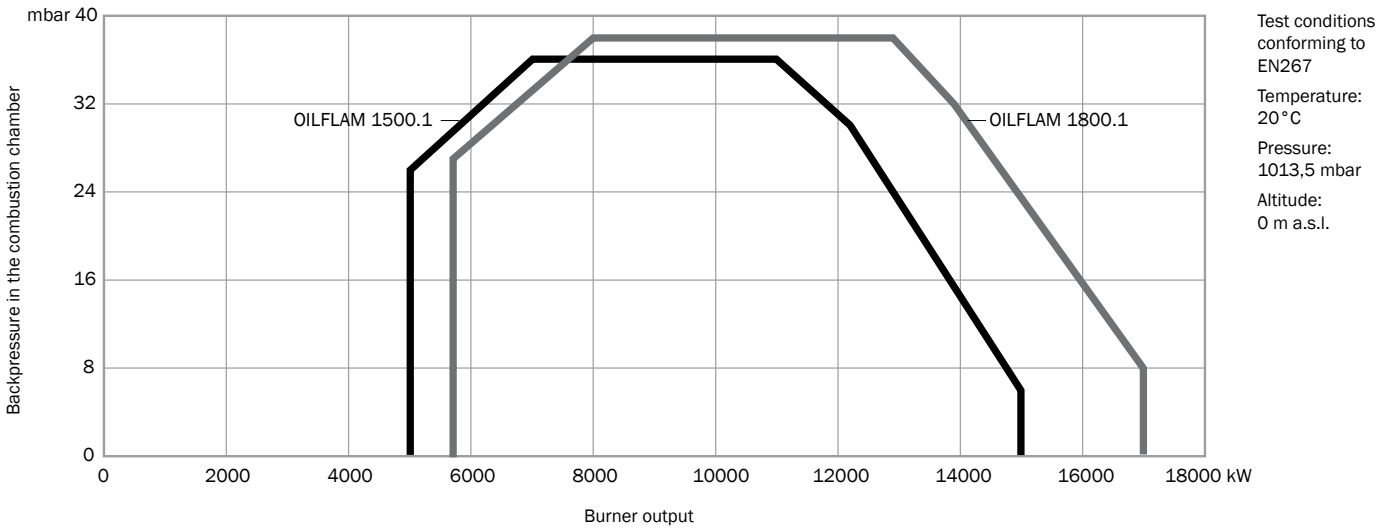

**TECHNICAL DATA**

	Burner output (kW)	Flow rate (kg/h)	Power supply	Resistance (kW)	Motor (kW)	Operation
<b>OILFLAM 1500.1</b>	5000 - 15000	440 - 1319	3/400V/50Hz	75	45	PR, PRE
<b>OILFLAM 1800.1</b>	5700 - 17000	501 - 1495	3/400V/50Hz	75	55	PR, PRE

**OVERALL DIMENSIONS**

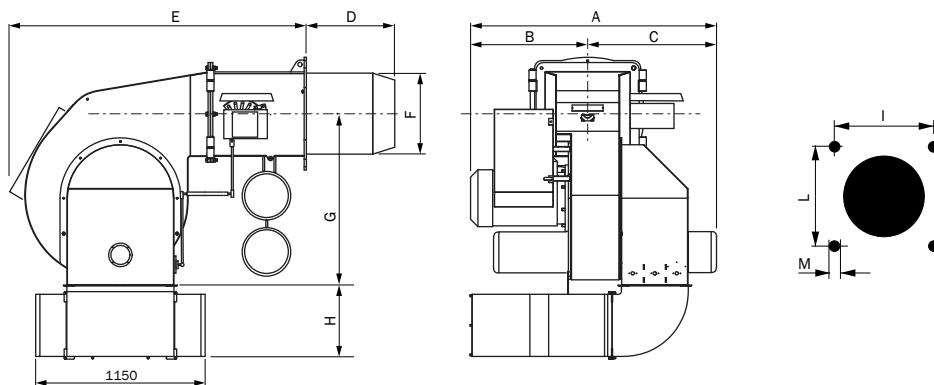

Dimensions in mm  
 Head length: D short / D1 long  
 \*: with silencer (optional)

	A	B	C	D	D1	E	F	G	H*	I	L	M
<b>OILFLAM 1500.1</b>	1948	860	1088	590	-	1910	550	1167	530	620	620	M20
<b>OILFLAM 1800.1</b>	1948	860	1088	590	-	1910	550	1167	530	620	620	M20





**HEAD OFFICE:**  
Via Roma, 64  
31023 Resana (TV)

**REGISTERED OFFICE:**  
Viale A. Merloni, 45  
60044 Fabriano (AN)

**Tel.: +39 0423 719500**  
**Fax: +39 0423 719580**  
**Email: [export@ecoflam-burners.com](mailto:export@ecoflam-burners.com)**

Company subject to the direction and coordination of Ariston Thermo SpA. Via A. Merloni, 45 - 60044 Fabriano (AN) - CF 01026940427

**Version 1.1 - 02/10/2017**

ECOFLAM Bruciatori S.p.A. reserve the right to make any adjustments, without prior notice, which is considered necessary or useful to its products, without affecting their main features.